

WL28

Articulated Wheel Loaders



**WACKER
NEUSON**
all it takes!



The compact and powerful wheel loader

Hardly any room on the construction site? No problem for the wheel loader WL28. Our powerful transport helper is impressive in all operator's cabs with a flawless view of the working area. Even though the machine is compact and maneuverable, it has a tipping load of 1.6 tons. Thus, even moving a pallet of sett paving stones is no problem. But also in terms of safety and comfort, you can count on the WL28. For example, the machine automatically comes to a standstill as soon as it is no longer in motion, thanks to the electric parking brake with hill hold function.

- Electronically regulated drive system for optimum performance and thrusting force
- More productivity and comfort with four different driving modes
- New operating concept increases comfort for the end user
- Powerful hydraulics options for sensitive control and operation of various attachments

WL28 Technical specifications

	Engine standard	Engine option	Engine option
Engine / Motor			
Engine / Motor manufacturer	Yanmar	Yanmar	Yanmar
Engine / Motor type	3TNV80FT	3TNV86CHT	3TNV86CHT
Cylinder	3	3	3
Engine performance kW	18.4	33.3	40.1
at rpm maximum rpm	2,600	2,600	2,600
Displacement cm ³	1,226	1,568	1,568
Coolant type	Water	Water	Water
DEF Type	-	DOC/DPF	DOC/DPF
Emission standards stage	V	V	V
Electrical system			
Operating voltage V	12		
Battery Ah	77		
Alternator A	80		
Weights			
Operating weight kg	3,000		
Tipping load with bucket - machine straight kg	1,910	2,640	
Tipping load with bucket - machine at angle kg	1,600	2,220	
Tipping load with pallet fork - machine straight kg	1,550	2,140	
Tipping load with pallet fork - machine at angle kg	1,310	1,800	
Vehicle data			
Bucket capacity Standard bucket m ³	0.42		
Traction drive	electronically regulated		
Axles	PA940		
Drivers cab (optional)	FSD (EPS, cabin)		
Speed (optional) km/h	0-20 (30)		
Speed Level	2		
Standard tires	12-16.5 BKT SkidPower ET 0		
Hydraulic system			
Driving hydraulics - operating pressure bar	380		
Operating hydraulics - operating pressure bar	210		
Operating hydraulics - discharge capacity at 18.4 kW l/min	41.6		
Operating hydraulics - discharge capacity (optional up to) l/min	84		
Filling capacities			
Fuel tank capacity l	50		
Hydraulic oil tank l	30		
Sound level			

	Engine standard	Engine option	Engine option
Average sound power level L _{WA} dB(A)	99		
Guaranteed sound power level L _{WA} dB(A)	101		
Specified sound pressure level L _{pA} dB(A)	84		

FSD = operator's canopy EPS = Easy Protection System (fold-down operator's canopy) DOC = diesel oxidation catalyst DPF = diesel particulate filter, tipping load calculation according to ISO 14397-EN474-3

WL28 Dimensions

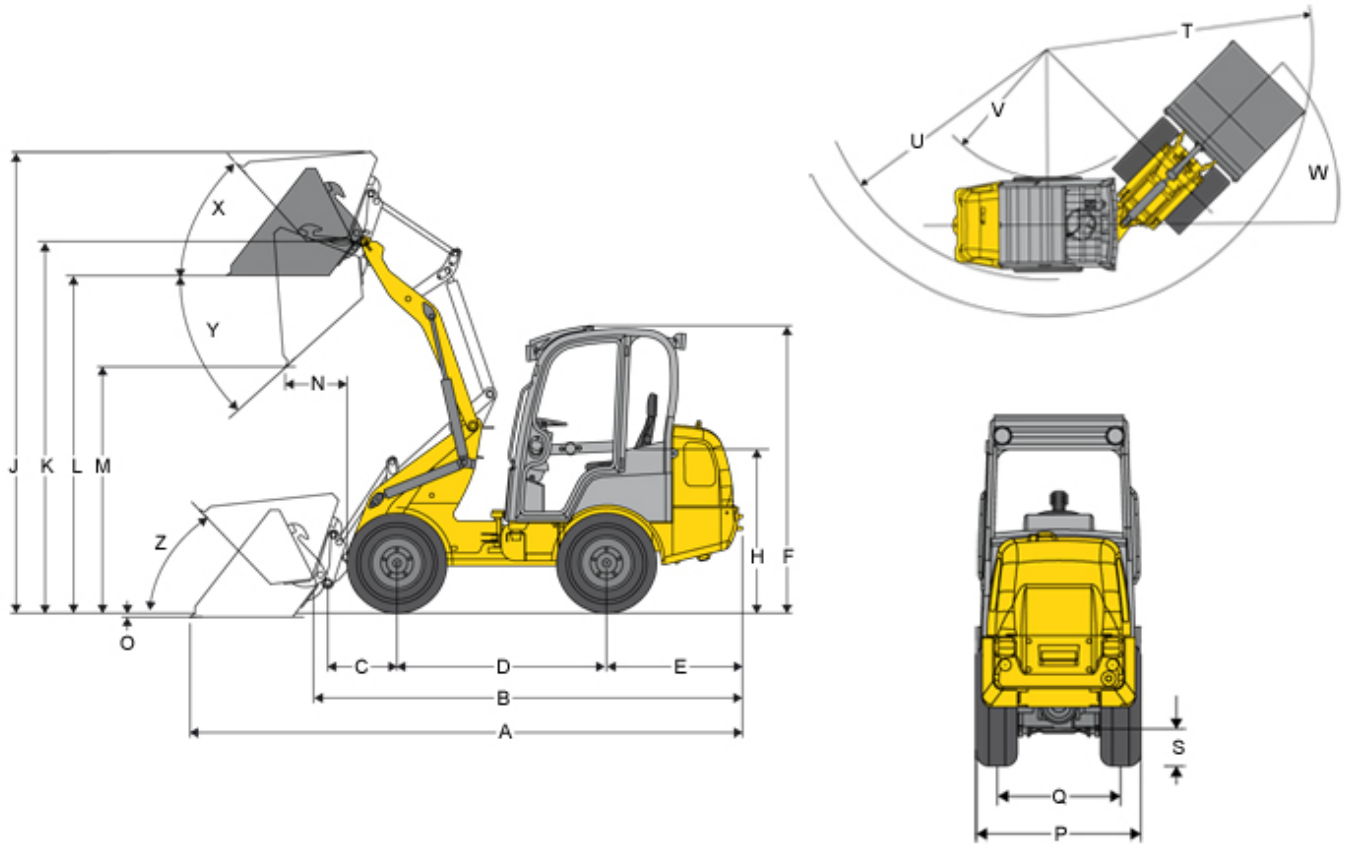

A	Overall length	4,520 mm
B	Overall length without bucket	3,710 mm
C	Bucket pivot point to axle center	670 mm
D	Wheelbase	1,760 mm
E	Rear overhang	1,230 mm
F	Height with operator's canopy	2,340 mm
	Height with fold-down operator's canopy (EPS)	2,395 mm
	Height with fold-down operator's canopy (EPS), folded-down	1,890 mm
	Height with cabin	2,350 mm
H	Seat height	1,350 mm
J	Total operating height	3,210 mm
K	Stroke height max. - bucket pivot point	2,560 mm
L	Overhead loading height	2,240 mm
M	Dump height max.	1,700 mm
N	Range with M	520 mm
O	Scraping depth	130 mm
P	Overall width	1,250 mm
Q	Track width	940 mm
S	Ground clearance	270 mm
T	Radius maximum	3,200 mm

U	Radius at outer edge	2,800 mm
V	Inside turning radius	1,510 mm
W	Articulation angle	45 °
X	Bucket rollback at max. stroke height	47 °
Y	Dump angle	41 °
Z	Bucket rollback at ground level	50 °

Please note: that product availability can vary from country to country. It is possible that information / products may not be available in your country. More detailed information on engine power can be found in the operator's manual; the stated power may vary due to specific operating conditions. Subject to alterations and errors excepted. Applicable also to illustrations.

Copyright © 2020 Wacker Neuson SE.